

Thunderbird Specialists

COASCO

SINCE 1969

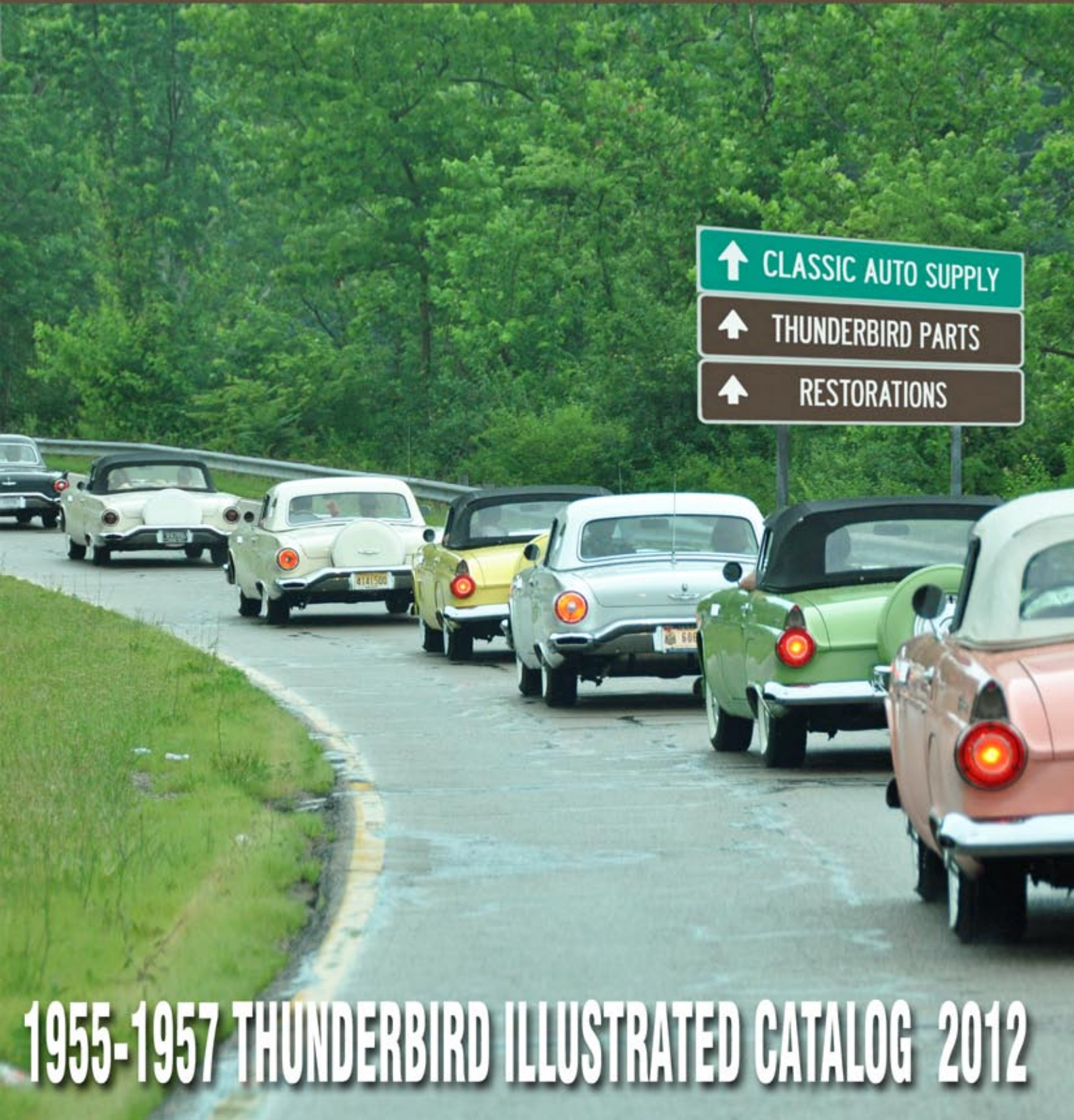

1955-1957 THUNDERBIRD ILLUSTRATED CATALOG 2012

CLASSIC AUTO SUPPLY CO., INC.

CASCO HISTORY - A FAMILY TRADITION

It didn't start out to be a business. We didn't buy a building, slap a sign on it and announce to the world "Here we are - buy your T-Bird parts from us" nor did we even start out as a planned business venture. Bill Brown was an engineer and product manager for GE. However, he was also a "car nut" and enjoyed working on cars. At the suggestion of his wife Sue, Bill purchased a '57 T-Bird that needed a lot of work. This was in 1968. As the restoration process progressed, Bill found that there were many parts that he needed that weren't available for his own car, and as a service to other T-Birders he found sources and had these parts reproduced. At that time, there were few T-Bird parts vendors and Bill only reproduced parts that were not available elsewhere.

The parts inventory grew and began to consume every available nook in Bill & Sue's house. The glass production took over the garage, Sue's oven was being used to bake grommets, and a makeshift order processing center was set up among the parts in the basement. It soon became clear that either the T-Bird parts would have to go or Bill and Sue were going to have to move. So in 1975, after quitting his position at GE, Bill purchased the buildings of an abandoned lumber company and CASCO moved to its present location. As the business grew, more and more parts were manufactured by CASCO's growing force of craftsmen. CASCO manufacturing now covers over 3000 square feet and includes manual and CNC milling, turning, cutting, bending, punching, and welding machines.

In 1979, after having a bad experience with a restoration facility on Bill's '66 Bird, Bill & Sue decided to open their own restoration business. This turned out to be a double benefit because the restoration work became an in - house application lab for testing and improving the parts being developed for sale.

Today, CASCO is managed by Bill and Sue's son Jim and his wife Betsy. The family tradition of integrity and service continues. Over 3500 items are listed in this catalog and our 13 employees are ready to serve your Classic T-Bird needs.



HOURS OF OPERATION

PARTS DEPARTMENT - 8:00 - 5:00 EST, Monday - Friday

RESTORATION DIVISION - 8:30 AM TO 4:30 PM Eastern Time - Monday through Friday

SATURDAY HOURS - Please call for an appointment

PHONES: PARTS (740)622-8561 / RESTORATIONS (740)622-9700 / FAX (740)622-5151

TOLL - FREE ORDER LINE (800)374-0914 TOLL - FREE FAX LINE - (800)513-5806

E-mail: sales@classictbird.com **WEB ADDRESS:** www.classictbird.com

Postal & Shipping Address: 795 High Street, Coshocton, Ohio 43812



FRONT FENDERS & HOOD

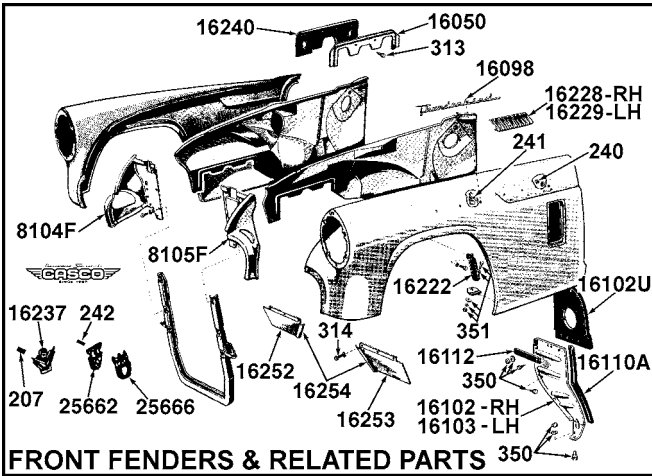

FRONT FENDERS & RELATED PARTS

8104F	Deflector - RH Side - Fiberglass	121.45
8104RP	Repair panel - Radiator deflector RH.....	282.65
8105F	Deflector - LH Side - Fiberglass	121.45
8105RP	Repair panel - Radiator deflector LH.....	282.65
16050	Metal Retainer for Apron Seal (16240).....	20.49



*16098	Thunderbird Script - 57 - W/Attach. Parts	26.50
--------	---	-------

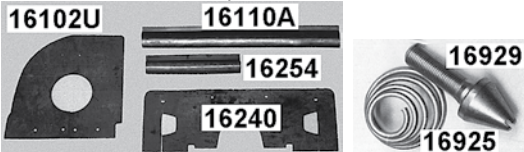

16102U	Shield - Upper Rear - Front Fender Splash Shield - Rubber - 56/57 - 2 Used/Car.....	4.20
16102	Splash Shield - Steel - Lower Rear - 56/57 RH.....	47.95
16103	Splash Shield - Steel - Lower Rear - 56/57 LH.....	47.95
16110A	Weatherstrip - Front Fender Rear Splash Shield - 56/57 - Set 2	5.98
16112	Plate - Upper Rear Splash Shield Retaining	1.60
16222	Brace - Fender to Apron.....	6.30



*16228	Louver Trim - RH.....	27.30
*16229	Louver Trim - LH.....	27.30
*16237	V - 8 Emblem - Body Side 55 W/Attaching Pts	15.72
16240	Seal - Front Fender Apron Shield - Each	4.15
16252	Splash Panel - Lower - Apron to Frame RH - Does Not Include 16254	12.95
16253	Splash Panel - Lower - Apron to Frame LH - Does Not Include 16254	12.95
16254	Weatherstrip - Front Fender Apron to Frame - Set 2	3.45

Emergency Hood Release Tool TL9
See page 57

HARDWARE KITS for this area - Complete List - Page 40

146	Hood Release Cable Bracket to Dash - 4 pcs.....	1.55
146A	Hood Rel. Cable Retainer to Firewall - 6 pcs	1.75
207	Y - Block Emblems - 55 - 4 pcs	1.50
*240	Louver Trim to Front Fenders - 12 pcs.....	2.20
*241A	Thunderbird Scripts to Body - 55/56 - 8 pcs.....	2.60
241B	Thunderbird Scripts to Body - 57 - 10 pcs.....	2.90
*242	Crest Medallion (25666) - With Pad - 3 pcs. One Kit Needed for Each Medallion.....	1.25
243	Cowl Side Vent Door (Outside) To Hinge and Hinge to Fender - 12 pcs.....	1.85
244A	Hood Hinge to Bracket - 8 pcs	1.95
244B	Hood to Hood Hinges - 12 pcs	1.95
*245	Hood Emblem (16607) to Hood - Includes 16873 Spacers - 8 pcs	5.45

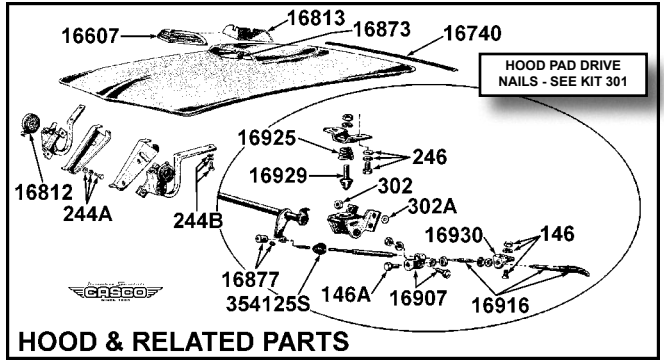

HOOD & RELATED PARTS

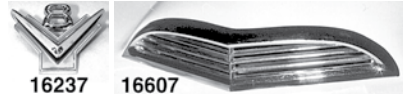

*16607X	Emblem - Front Hood - Quality Reproduction	69.95
16612A	Pad Set - Hood Anti - Rattle - Very Difficult to Install	6.25

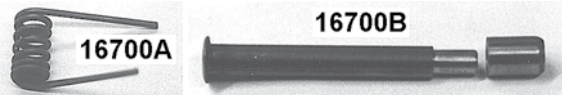

16700A	Spring - Inside Latch Assembly	3.70
16700B	Repair Pin - Hood Latch Release.....	10.45
#16740A	Pad - Hood - 55 - without drive nails	4.95
#16740B	Pad - Hood - 56/57 - without drive nails	4.95

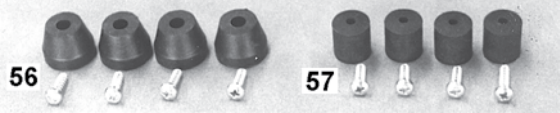

#16758A	Hood Bumpers With Attaching Screws - 4 Sets - 56...(Not Used On 55's).....	5.20
#16758B	Hood Bumpers With Attaching Screws - 4 Sets - 57 - Bumpers have Washer Insert	7.95
16812	Spring - Hood Hinge.....	10.50
16813	Hood Block Off Plate.....	6.30
16873	Spacer - Hood Ornament Stud.....	9.95

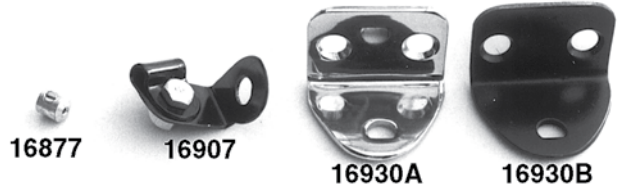

16877	Clamp - Hood Catch Cable - Plated - W/Screw	4.80
16907	Bracket - Hood Release Cable at Firewall	13.15
16916A	Cable - Hood Release - With Original Handle.....	29.23
16925	Spring - Hood Latch - Cad Plated	3.10
16929	Dowel - Hood Lock - Cad Plated.....	10.25
16930A	Bracket - Hood Release Cable - Chrome.....	13.95
16930B	Bracket - Hood Release Cable - Black - 57	8.45
*25662	Medallion - Front Fenders - 56	18.89
*25666	Retainer for 25662 - Chrome	18.95

246	Hood Latch Pin Brackets to Hood - 12 pcs	1.95
301	Hood Pad (drive nails) to Body - 7 pcs	8.35
302	Hood Locks (16700 - 1) - Original Nuts - 8 pcs	2.15
302A	Washers - Between Hood Locks & Firewall - 8 pc	2.70
313	Apron Shields (16050) to Apron - 8 pcs	2.85
314	Lower Splash Shield to Apron - 12 pcs	5.40
350	Lower Rear Splash Panels to Aprons, Upper Shields and Fenders - 56/57 - 30 pcs	5.35
351	Fender Support Brackets to Aprons and Fenders - 12 pcs	3.05
352	Side Vent Spacer Duct to Aprons and Fenders - 36 pcs	4.00
900	Staples - Like Original for Seals and Weatherstrip - Pkg 50.....	8.75
900A	Staples - as 900 but Pkg 12 Only.....	2.75

HOW CAN WE HELP YOU ENJOY YOUR THUNDERBIRD?

❑ **Parts** Celebrating our 43rd year, we have supplied quality new and reproduced parts and accessories for your Classic Thunderbird since 1969. Prompt attention to your orders and the fairest possible pricing has been the basis of our business. We, like most of you, are hobbyists who love Classic Thunderbirds. We strive to treat you and your order as we would wish to be treated.

❑ **Technical Assistance** We welcome the opportunity to share with you the knowledge we have gained over the years as a result of researching parts and painstaking restorations. Just call (740) 622-9700 between 9:00 and 4:00 M - F. Or submit your inquiry via email at techinfo@classictbird.com

❑ **Complete Restoration** Since 1979 we have been restoring Classic Thunderbirds for street and show. Because we specialize in '55 - '57 T-Birds we have the special tools and fixtures which allow our expert staff to be efficient in producing top quality work. We are big enough to serve you expertly and efficiently and small enough to give you and your Thunderbird the personal attention you deserve. Stop by or call our restoration shop manager at (740) 622-9700.

❑ **Partial Restoration** If your Bird needs only a partial restoration such as a new interior, new wiring, major or minor engine work and rebuilding, dash recovering, engine compartment refurbishing, convertible or hardtop work, trunk reconditioning, or just fixing a few small rust spots, you name it - we are here to help.

❑ **Routine Repair Work** If your Bird needs a brake job, exhaust system, shocks, glass replacement, or a tune - up you can put your car in the hands of experts where you can be assured of quality work by knowledgeable and careful workmen.

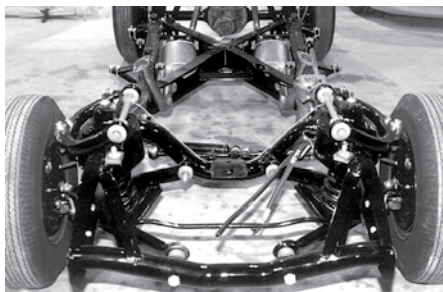

The CASCO Guarantee

All CASCO parts are guaranteed! If you are not satisfied with any item you may return it and we will promptly exchange it or send you a refund. (See details on back)



Order PH 1-800-374-0914
Toll
Free FX 1-800-513-5806

International phone 740-622-8561 fax 740-622-5151
 Technical Questions? Call our technicians ph 740-622-9700

Ordered by: Check if change of address **Please ship to:** Check if change of address

This time only Gift

Name _____

Address _____

City _____

State _____ Zip _____

Daytime Phone No. _____

E-mail address: _____

Name _____

Address _____

City _____

State _____ Zip _____

Backorder? yes no (details on back)

	QTY.	CATALOG PART NUMBER	YEAR BIRD	DESCRIPTION	Pg.	PRICE EACH	TOTAL PRICE
1							
2							
3							
4							
5							
6							
7							
8							
9							
10							
11							
12							
13							
14							
15							
16							

Thank You!

Comments:

Subtotal
Quantity Discount (See back for details)
7% Sales tax (Ohio shipments only)
Shipping & Handling 12% of subtot \$10min \$35max - Ohio Sales - 10% of subtotal \$7min \$25max
Total

Yes! Please send CASCO's e - newsletter to: _____

Yes! Please send me information on Classic Thunderbird Club International.

Method of Payment: Charge my credit card:

Card No. _____ CVV: _____



Expires: ____/____/____

Check or M.O. \$ _____

ORDERING INFORMATION

THE CASCO GUARANTEE

If you are dissatisfied with any new item you may return it along with a MERCHANDISE RETURN FORM, which can be found on page 79 or on our web site, and a copy of the invoice within 60 days of receipt for a full refund less shipping charges. Returned items must be in good, as received, condition. Used parts will be subject to a 25% restocking charge. We do not accept returned electrical parts. After 60 days, returns of new parts will be subject to a 10% restocking charge. Returned items without invoices or invoice numbers may be charged a \$5.00 search charge. Items without purchase confirmation cannot be accepted. We will not accept returns by COD or postage due. If CASCO is at fault we will refund reasonable return shipping.

TECHNICAL ASSISTANCE

So that we may serve you more efficiently, please use our technical assistance line for technical help. Phone (740) 622-9700. You can also email CASCO technicians directly at techinfo@classictbird.com

TELEPHONE & FAX ORDERS

We accept Visa, MasterCard, Discover Card, and Wire Transfer telephone orders
Toll - Free Order Line (800) 374-0914 - Toll - Free Fax Line (800) 513-5806
Local & international customers please phone (740) 622-8561 or fax (740) 622-5151
Bank charges for wire transfers are the responsibility of the customer (normally \$15 - \$20).

INTERNET ORDERS

Shop 24-7 on our web store. Go to www.classictbird.com and click on "On - line Store". We accept Visa, MasterCard, and Discover Card. Order with confidence - we make every effort to keep your transaction secure.

MAIL ORDERS

We accept personal checks, money orders, bank checks, Visa, MasterCard, and Discover Card. Please do not send cash. Please provide complete description of the parts you need. Shipments may be held for two weeks for personal checks to clear your bank. Returned checks will be assessed a \$25 NSF fee. Send to CASCO, 795 High Street, Coshocton, OH 43812
Orders shipped COD will require certified funds in the form of a Money Order or Cashiers Check ONLY. UPS & Fed Ex will not accept cash. COD charges of \$12.00 will be added to each package shipped COD.

CREDIT & DEBIT CARD ORDERS

When an order is initially placed, we perform a pre - authorization on your credit card for an amount sufficient to cover any potential charges associated with your order. This pre - authorization allocates a portion of your line of credit towards the purchase from us. Due to the restrictions of credit card processing, the pre - authorization amount is normally slightly higher than the exact order amount that is finally charged to the credit card. The exact amount is charged to the credit or debit card at the time the order is shipped from our facility. If we do not use the pre - authorization for some reason, (order cancelled, item sold out, etc.) the pre - authorized amount will be restored to your credit card's line of credit in the amount of time determined by the issuing bank. The card issuing bank may hold the original pre - authorization amount for some period of time even after we have already charged the card. Please contact your bank to find out what their policy is with regard to releasing your funds on a pre - authorization. Only your bank can decide when to release that amount back to your account.

BACKORDERS

If you order an item which we expect to be able to ship within 30 days and that item is not immediately available, we will backorder the item. Please note or advise if you *do not* wish to have items backordered. Backordered items will be sold at the price in effect at the time of shipment. Shipping charges will be added to each shipment, including any backorders, as shown below (12% of backorder subtotal - \$10.00 min. and \$35.00 max.).

QUANTITY DISCOUNT

A quantity discount will be offered on any shipment of new parts and upholstery to one location which meet the following two criteria: the *merchandise total is over \$1000 and payment is made in advance in cash or by bankcard.* Orders paid by **bankcard** (Visa, Mastercard or Discover) or **personal check**, will be extended a 7% discount off the merchandise. Orders paid in advance by **cash** or **cashiers check** will be extended a 10% discount. Discount does not apply to special order items, used parts, disc brake kits, or restoration shop billing. No additional shipping charges for backordered items on quantity discounted orders.

SHIPPING CHARGES

NORMAL SURFACE shipping charges within the continental United States will be calculated as follows: 12% of subtotal with a \$10 minimum and a \$35 maximum for each shipment. Ohio sales: 10% subtotal with \$7 min. and \$25 max.

ALL OTHER shipping methods including overnight/express services, priority mail, freight, etc. will be charged actual shipping cost, a reasonable box & pack charge plus a \$5.00 special handling fee. Truck and Air Express shipments will be sent freight collect.

OVERSEAS shipments may be charged a \$5.00 documentation charge in addition to all other charges. Shipments outside the continental United States, please specify your preferred method for shipping.

OHIO SALES TAX

Ohio sales tax is charged on all pickup orders and all orders shipped to a location in the state of Ohio.

PRICES & AVAILABILITY

All prices are subject to change without notice. Availability is subject to prior sale.

LIABILITY

The seller, CLASSIC AUTO SUPPLY CO. INC. hereby expressly disclaims all warranties, either expressed or implied, including any implied warranty of merchantability or fitness for a particular purpose, and CLASSIC AUTO SUPPLY CO. INC. neither assumes nor authorizes any other person to assume for it any liability in connection with the sale of this merchandise.

The liability of CLASSIC AUTO SUPPLY is limited only to the replacement of defective parts. No labor claims will be honored.

- Accessories
- Books
- Brakes
- Bumpers
- Car Care
- Cockpit Area & Glass
- Cooling & Body Front
- Doors
- Electrical-Charg & Starter
- Electrical-Ignition
- Electrical-Lamps & Body
- Engine & Mounts
- Exhaust
- Front Fenders & Hood
- Front Suspension
- Fuel System
- Hardware
- Hardware Kits-All
- Heater
- Mirrors
- Paint & Adhesives
- Radio & Antenna
- Rear Axle & Driveshaft
- Rear Quarters & Skirts
- Rear Springs
- Repair Panels
- Shock Absorbers
- Steering
- Tires & Wheels
- Tools-Special
- Tops
- Transmission & Shifters
- Trunk
- Upholstery
- Vent Systems
- Wipers & Washers



Classic Auto Supply Co., Inc.
795 High St.
Coshocton, Ohio 43812

PRESORTED
STANDARD
U.S. POSTAGE
PAID
LOUDONVILLE, OHIO
PERMIT NO. 38

Change Service Requested

ORDERS - USA & Canada
Phone: (800) 374-0914
Fax: (800) 513-5806

INTERNATIONAL & Local
Phone: (740) 622-8561
Fax: (740) 622-5151

TECHNICAL HELP
Phone: (740) 622-9700

E-mail: casco@classictbird.com
Website: www.classictbird.com

Electronic Newsletter

Our electronic news letter includes new CASCO reproductions, technical tips, special sale prices, and other Thunderbird and CASCO news items. Sign up through our web site or simply give us a call and we can add your e-mail. By joining, you will be eligible for our monthly CASCO gift certificate drawing.



Club Participation

CASCO has consistently supported the TBird hobby through local and national car clubs. We believe that participation in a club is a sure way to maximize the enjoyment of our little birds. If you are not a member of a club, we encourage you to consider joining today. Three of the national clubs catering to T-Birds are:

CTCI: www.ctci.org
ITC: www.intl-tbirdclub.com
VTCL: www.vintagethunderbirdclub.net

Parts Department:
Monday - Friday 8:00 to 5:00 EST
Phone 740/622-8561
24 hr Ordering: www.classictbird.com

Restoration Department:
Monday - Friday 8:30 to 4:30 EST
Phone 740/622-9700



Order Phone: 800-374-0914

© 2012 Classic Auto Supply Co. Inc
Printed in U.S.A.